

Ultraviolet Monitoring System

Part Numbers
UV/MS-1 V3
UV/MS-2 V3

Installation And Operations Manual



2 System Description

The Wyckomar UV Monitor measures true UV intensity at 254 nm, which is the effective germicidal wavelength for UV treatment of drinking water. It continuously monitors lamp output inside the chamber, regardless of whether or not water is flowing through the system. UV intensity is constantly displayed in real-time on the meter face. When the UV intensity emitted by the lamp drops below the alarm-set point (70% of new lamp UV output - this level is factory pre-set), the audible alarm will sound and the output relay is de-energized. The UV sensor will remain active. The factory setting for the output relay is NO (normally open), which is used to operate a solenoid valve. The output can be reversed with a jumper setting to NC (normally closed) for use with a remote alarm.

The system consists of 2 basic components: the sensor (with lead and connector) and the controller. The system is also shipped with a compression nut that replaces the existing view-port compression nut.

Sensor

There are two sensor ports on the monitor. For a single lamp system, the sensor plug is inserted into sensor port #1. Sensor port #2 is deactivated in this case and remains empty. The UV sensor(s) is inserted into the view-port of the UV reaction chamber, and held in place by a compression nut.

When the monitor is connected to a dual lamp system such as the UV-5000, the meter reading displays the UV output of the least powerful lamp (not the sum of the two lamps). This is important when determining when to change the lamps.

System Description

The cable provided with the sensor (sensor lead) is approx. 6 feet long (8 feet extension cable available). All the sensor components are hermetically sealed. Do not attempt to remove the lead from the sensor, this will influence the factory pre-set calibration and will void the warranty.

Controller

The controller is inside an Aluminum box and has been designed to operate indoors. It has a standard IEC-320 input power port (120 or 230 Volt, 50/60 Hz), supplied with the appropriate power cord, output for a solenoid valve (output cable optional), 2 sensor input ports, and an analogue intensity meter face on the front. If the monitor is exposed to adverse conditions (humidity, dust, fire hazard), it has to be enclosed in a properly sealed enclosure.



4 Installation

WARNING - Unplug the power cable of the UV system from the outlet and drain the UV chamber before installing the UV monitor.

1. Mount the controller in a suitable location above the UV unit on the wall, away from possible water sources, and close enough to the UV reaction chamber for the sensor cable to reach.
2. Remove the compression nut from the view-port of the UV reaction chamber.
3. Remove all parts from inside the view-port. There is a plastic compression bushing, a glass disc and two o-rings. The original compression nut and all the contents of the view-port can be put aside, they are not needed any more (save parts if sensor needs to be serviced).
4. Insert the sensor into the view-port, making sure that the o-ring is sitting properly in the groove. Screw down the provided compression nut (hand tight, do not over-tighten). This assembly has to be sealed properly.
5. Attach the sensor cable to the appropriate sensor port on the controller. In single lamp units, this is port #1. Port #2 is used for a second lamp in multi-lamp UV systems.
6. Connect the power cable to the Input port on the controller and into nearby outlet. The alarm will sound and the UV intensity meter will read approx. 20% if the UV system is off.
7. Plug in the power of the ballast(s) to start up the lamp(s). The alarm in the monitor should stop 1-2 minutes after the lamp(s) come(s) on. The meter face on the monitor should indicate full scale (assuming the reaction chamber is equipped with a new lamp).
8. Turn the water back on and check that the view-port assembly is properly sealed.

Installation

Please note that all electronic devices (ballast, monitor) should be mounted above the UV system with a drip loop in the connecting cables, in order to keep moisture away from the electronics if there is a leak or during maintenance.

Handle sensor with care – UV sensors damaged at installation or while cleaning are not covered under warranty.

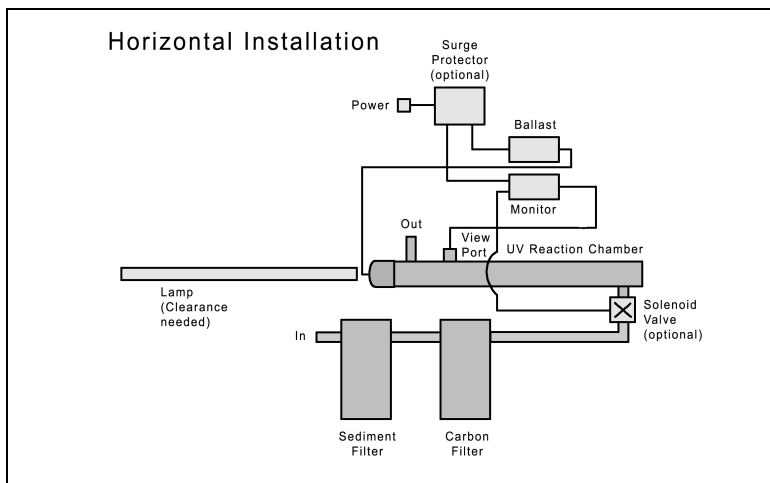
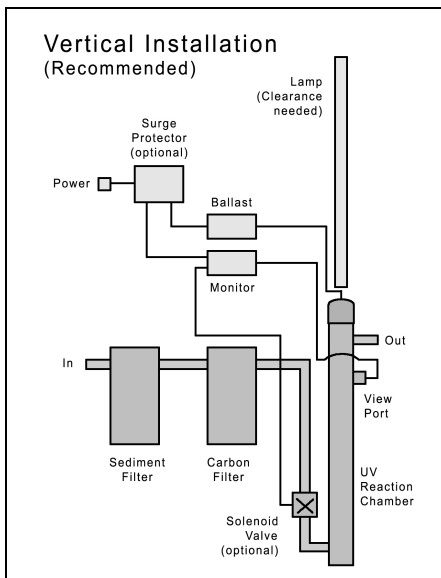

6 Calibration

This UV monitor has to be calibrated before use. Also, upon lamp change, the monitor has to be re-calibrated, according to the following procedure:

Before beginning the calibration, be certain that the lamp and the quartz sleeve/dome are clean (please refer to the UV Manual). Refer to the dimensional drawing on page 9 for locations of the calibration ports.

1. With a small Phillips or slot screwdriver, adjust the potentiometers via calibrator port 1 and/or 2. Turn fully clockwise.
2. Plug in controller. The alarm will sound and the meter face will register approx. 20% UV intensity.
3. Plug in UV unit. The UV alarm will continue to sound for about a minute as the UV lamp warms up and intensity increases. Let the UV run for approx. 15 minutes before continuing.
4. Adjust potentiometer (pot) for sensor #1 by turning it counterclockwise until the meter face reads slightly less than 100%, then turn pot clockwise until the needle just reads 100%.
5. Repeat step 4 for sensor #2 if applicable.

Calibration is now complete.

This procedure has to be repeated each time the lamp is changed.

Frequently Asked Questions

Q: “My alarm sounds when no water is flowing”

A: This can be due to the water inside the reaction chamber of the UV unit heating up – the output of UV light decreases in hot water.

Solution: Run water through the system until it returns to normal temperature **or:** Install a Thermal Relief Valve (purge valve) at the out-port of the UV unit.

Q: “I’m not getting more than 20%.”

A: 20% is equivalent to no reading. This indicates that the monitor is working, but the sensor is not detecting light.

Solution: Check that the UV light is on, check all electrical connections between sensor and monitor. Check if there is corrosion or scale buildup inside the sensor + replace.

Q: “The monitor reads less than 70%, although there is a new lamp in the UV unit.”

A: (1) The sleeve may be coated with deposits.

A: (2) The UV unit could have been mounted with the view-port at the top and now air bubbles are collecting in the view-port.

A: (3) The pre-filtration may not be adequate (iron in the water or turbidity too high, both are known to obstruct the UV transmittance).

A: (4) The calibration may not have been performed on a new lamp.

Solution: (1) Clean the quartz sleeve with vinegar, then rubbing alcohol.

(2) Mount the UV unit so that the view-port is not the highest spot (see page 5)

(3) Install proper pre-filtration.

(4) Calibrate the monitor against the new lamp.

8 System Specifications

Display: analog 0-100% UV intensity (254 nm)

Operating Temperature Range: 0 to 41° C

(32 to 105° F)

Input Power: 115 VAC (+- 10%)

or 230 V VAC (+- 8%), 50/60 Hz (+- 2%)

Output: DPDT relay contacts

(max. 3-1/2 Amps / 115 VAC or 230 VAC)

Optional: Remote alarm output (consult manufacturer for jumper settings)

Fuse: 3.5 Amps MDL 250 VAC ¼" x 1-¼" Replaceable

Alarm indication: High-pitch noise

Size: 4-5/8" W x 6-5/8" L x 2-3/8" D

Parts List

Monitor	# 4-UV/MS-1 (120 Volt 50/60 Hz)
	# 4/UV/MS-2 (240 Volt 50/60 Hz)
Sensor assbly. (1 or 2)	# 4-35-3
Power Cord	indicate country of origin for part #
O-ring	# 11-6

Options

8' Extension Cable	# 4-EC8FT
Solenoid Valve	# 4-SVP
Remote Alarm	please inquire
Thermal Relief Valve	# 10-PV-BF-T (T-Fitting not supplied)

Parts and Service available from Authorized Dealer (please contact manufacturer for list of dealers)

Drawings

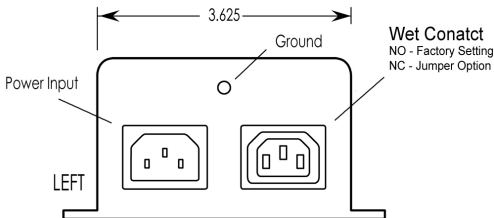
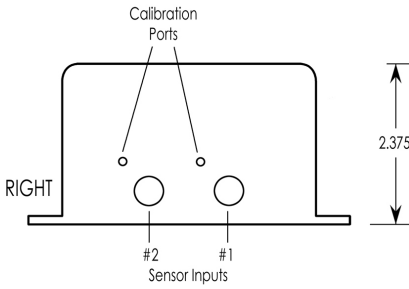
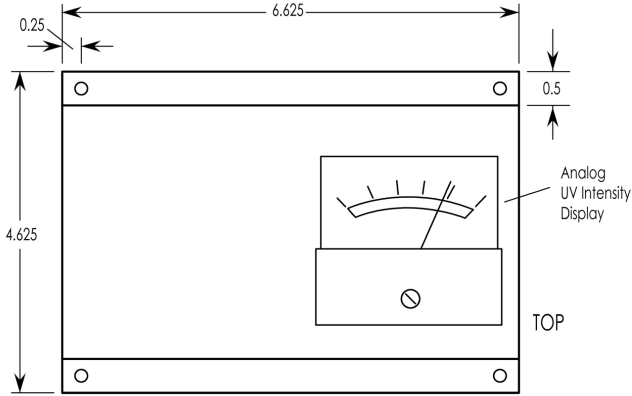

Wyckomar Inc.
UV Monitor
UV/MS-1 and -2
All measurements shown are in inches

10 Drawings

Sensor Plug

Cable
6 ft

Compression
Nut
Material: Delron

Strain
Relief

Oring

Sensor
Head

Oring

Outer
Bushing
Viewport
Material: 316SS

UV Reaction Chamber

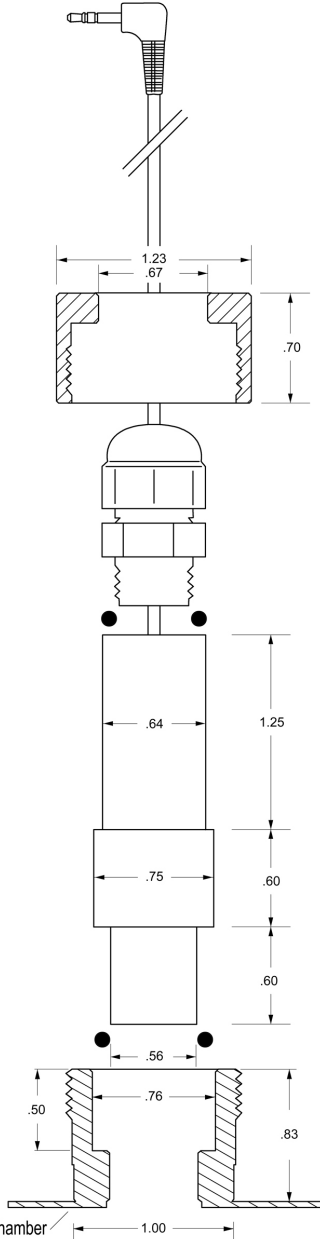

Wyckomar Inc.
Viewport

Units:
UV-700
UV-1200, UV-1500
UV-3000, UV-5000,
UV-6000
UV-100, UV-5007

Notes

Manufactured by

Wyckomar Inc.

111 Malcolm Road

Guelph, Ontario Canada N1K 1A8

Phone: ++1-519-822-1886

Fax: ++1-519-763-6580

Email: sales@wyckomaruv.com

www.wyckomaruv.com